

Mechanical clamps VCMC-R-QUICK

Clamping range 10 mm to 100 mm with quick adjustment

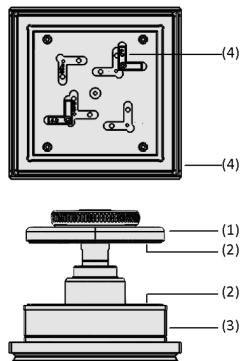

Mechanical clamps VCMC-R-QUICK



System Design Mechanical clamps VCMC-R-QUICK

Product Highlights

- Triangular clamping plate with tool-free quick adjustment enables shortest set-up times
- Clamping forces up to 700 N guarantee high holding forces even with narrow workpieces
- No additional medium required on the machine, as the clamping device is activated by the operating vacuum of the CNC machining centre
- Special friction materials on the clamping plate and clamping surface ensure that the workpiece is held securely even with high machining forces

Suitability for Industry Specific Applications

- Mechanically clamping system for CNC machining centers with vacuum grid table, suitable for all common grid geometries
- Particularly suitable for narrow and curved workpieces such as frame parts and window profiles
- For set-up, the clamp is positioned in the grid with mounting brackets and the clamping height is adapted to the workpiece with the tool-free quick adjustment
- Fixing the clamp and clamping the workpiece by activating the vacuum on the machine table

Design

- Triangular clamping plate (1), adjustable without tools in clamping height and bearing surface on the workpiece
- The clamping plate is lowered via the piston by activating the vacuum and clamps the workpiece
- Friction material (2) for optimizing lateral force absorption
- Main body made of aluminum (3) with interface to the grid table with mounting brackets and sealing frame (4)
- Interface to grid table with mounting brackets (4) and sealing frame (5)

Mechanical clamps VCMC-R-QUICK

Clamping range 10 mm to 100 mm with quick adjustment

Ordering Data Mechanical clamps VCMC-R-QUICK

Type	Part no.
VCMC-R-QUICK 150x130x100 30/40	10.01.12.04612
VCMC-R-QUICK 160x160x45 30/40/50	10.01.12.04763

Ordering Data Spare Parts Mechanical clamps VCMC-R-QUICK

Type	Spare Parts		Part no.
VCMC-R-QUICK 150x130x100 30/40	Clamping disc	SPAN-TELL 110 EXZ VCMC	10.01.12.04239
VCMC-R-QUICK 160x160x45 30/40/50	Clamping disc	SPAN-TELL 128x30 EXZ VCMC	10.01.12.04740
Type	Spare Parts		Part no.
VCMC-R-QUICK 160x160x45 30/40/50	Sealing frame	ISDR 150x150x13.5 R 30/50	10.01.15.00352
Spare Parts			Part no.
Sealing frame	ISDR 120x120x13.5 R 30/40		10.01.15.00353
Set of spare parts	ERS VCBL-R Winkel		10.01.12.02691

Ordering Data Accessories Mechanical clamps VCMC-R-QUICK

Type	Accessories		Part no.
VCMC-R-QUICK 160x160x45 30/40/50	Extension with hexagon	VRL-S M20x1x40.3	10.01.12.04374

Technical Data Mechanical clamps VCMC-R-QUICK

Type	Clamping range [mm]
VCMC-R-QUICK 150x130x100 30/40	10.0 ... 100.0 mm
VCMC-R-QUICK 160x160x45 30/40/50	15.0 ... 85.0 mm

Mechanical clamps VCMC-R-QUICK

Clamping range 10 mm to 100 mm with quick adjustment

Design Data Mechanical clamps VCMC-R-QUICK

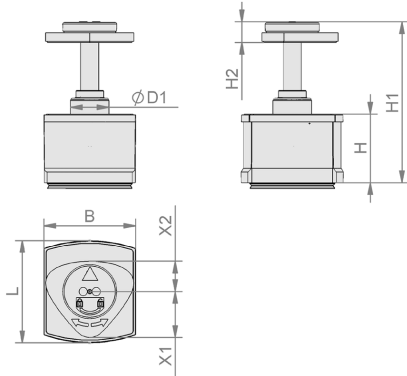

VCMC-R-QUICK 150x130

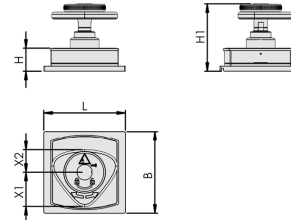

VCMC-R-QUICK 160x160

Mechanical clamps VCMC-R-QUICK

Clamping range 10 mm to 100 mm with quick adjustment

Design Data Mechanical clamps VCMC-R-QUICK

Type	B [mm]	[mm]	H [mm]	H1 [mm]	H2 [mm]	L [mm]	X1 [mm]	X2 [mm]
VCMC-R-QUICK 150x130x100 30/40	133.5	56	100	232.7	30.0	148.5	67	44
VCMC-R-QUICK 160x160x45 30/40/50	160.0	56	45	162.5	30.0	160.0	67	44